

FOSS

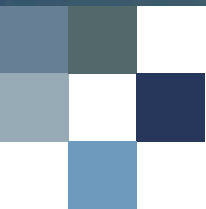

WPC & MPC Process Analysis
Get more out of your production with
High Resolution in-line analysis

ProFoss™

Dedicated Analytical Solutions



Get a clearer picture of your WPC & MPC production with High Resolution process analysis.

Let your production staff improve your business

Profit opportunities are waiting to be found in your ultra filtration process.

For instance, more accurate control of the Protein - Total Solids ratio content can increase earnings significantly. At the same time, improved product consistency can provide new pricing options.

Give your production staff the right tool in the form of a ProFoss™ integrated High Resolution process analysis solution from FOSS, and they can achieve increased yield and improved consistency.

Users of such solutions report a rapid return on investment with a typical payback time of less than twelve months.

Advantages of ultra filtration process control include improved yield and profit based on:

- Optimised Protein - Total Solids ratio content
- Consistent product quality
- Higher value products for your customers
- Reduced rework

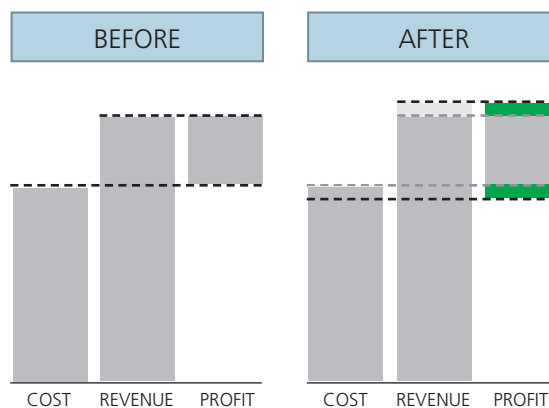

Stretch your profit zone: Production costs can be decreased and the higher product consistency will increase your competitiveness.

"FOSS is committed to process analysis because, quite simply, it is the future of food production. Tighter control of production is a sure way for you to improve both profit and customer satisfaction while minimising energy usage."

Peter Foss, President

The FOSS difference – dairy industry knowledge and experience

At the heart of any FOSS analytical solution is a simple and enduring concept: To give you just what you need to obtain accurate, timely information according to the demands of your production environment.

This is a principle that FOSS has followed for over 50 years. And that's why today, FOSS is unique in offering dedicated solutions for dairy process analysis and control. Our knowledge and experience ensures that your process analysis solution is right for your demands and can be applied quickly and easily to your production.

Investing in a process analysis solution

With any process analysis solution you are effectively putting your production in the hands of technology. FOSS is the right partner to provide a reliable solution that will run day in, day out and year after year.

FOSS dairy solutions offer:

- ☑ Proven technology for accuracy and trouble-free operations
- ☑ User-friendly interfaces allowing anyone in the plant to contribute to process control
- ☑ Service programs offering a range of options to suit your business. Get your service in a timely manner by fully trained local staff onsite and/or remotely through internet

FOSS Total Service Solutions

- FOSS is committed to providing complete and fully integrated solutions to customers
- Our relationship with you is a continuous partnership, not a time-limited occurrence
- FossCare™ Total Service Solutions are available at multiple levels according to your needs

FOSS

- World's leading provider of analytical solutions for the food, agricultural, chemical and pharmaceutical industries
- Helps customers to improve profit, product quality and food safety
- FOSS solutions are used for routine laboratory analysis as well as at-line and in-line process control
- Over 90 of the world's top 100 food and agricultural companies use FOSS solutions
- FOSS analysers are analytical solutions dedicated to specific process needs
- Strong global organisation with focus on growth
- Privately owned and financially stable

How to improve your WPC & MPC production

In process control, seemingly minor adjustments can lead to significantly increased yield and revenue. A FOSS in-line process analysis solution employing High Resolution technology gives you the accuracy you need to monitor and control your process accordingly.

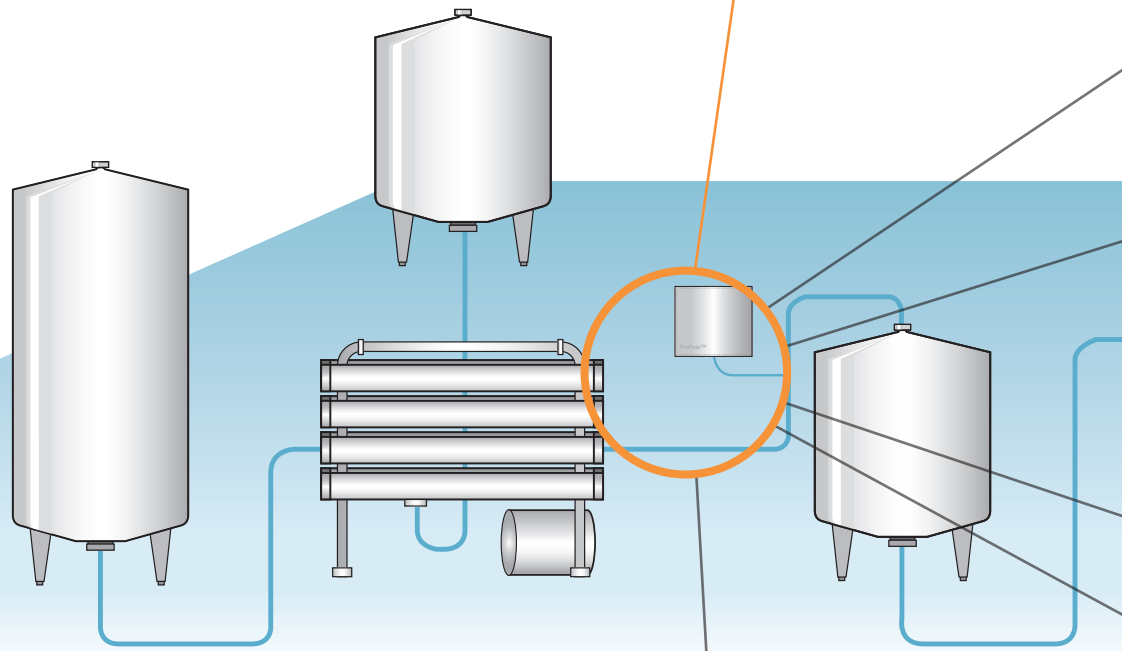

ProFoss™ – the optimal solution for ultra filtration process analysis

- Robust, process solution withstands water and vibration and complies with hygiene regulations
- Reliable and low maintenance – keeps on running for maximum uptime
- Results can be fed into your production/SCADA system and/or be presented on a screen in the production area for rapid adjustments of your process
- Full technical support and preventative maintenance options

Parameters

- Total Solids
- Protein
- Protein-Total Solids ratio

In WPC & MPC production the primary profit driver is to optimise the Protein - Total Solids level to increase yield and thereby revenue.

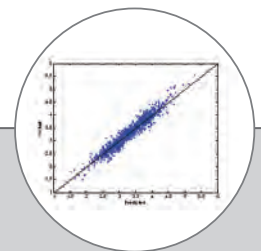

Process analysis advantages

- Production close to target specifications
- Increased yield
- Less rework and start up variation
- Optimised mass-balance

Production closer to target

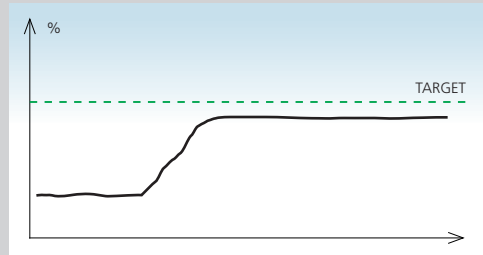

Reduce start up variation

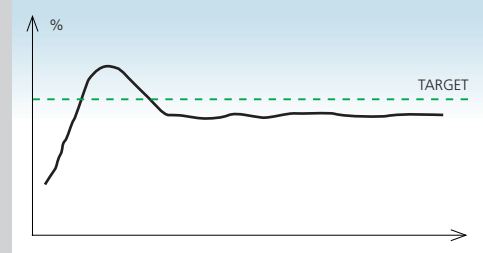

Alarms when out of spec production

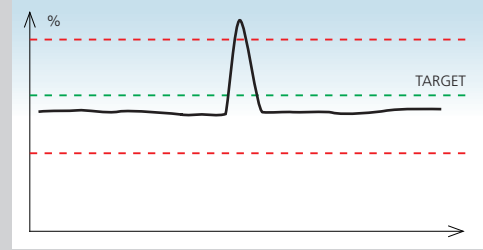

Typical analyser Installation point

- Installation after the final ultra filtration in order to validate and adjust final Protein - Total Solids ration
- Hygiene certified according to USDA



Dedicated sample interface

- Lateral transmittance interface connected directly to the pipe
- True in-line – no bypass – no waste
- No moving parts
- No hygiene compromises





ProFoss™ – High Resolution NIR technology

ProFoss™ is unique in employing a near infrared-based analysis technology known as High Resolution diode array analysis. The High Resolution technology ensures accuracy and reliability with measurements based on a high density of data points.

Accurate and continuous results

Measurement accuracy is in line with traditional laboratory analysis. However, results are presented continuously rather than a few times per day giving the opportunity for immediate adjustments to production.

This together with the dedicated WPC & MPC sample interface ensures you a total solution optimal for your process.

Quick and simple to implement

The High Resolution technology behind the accuracy of the ProFoss system also has benefits when implementing the system. Because measurements can be relied on to be the same across individual instruments and are highly stable over time, you can reduce the time and money spend on installation of individual analysers. The standardisation and stability of the solution, as well as the intelligent FOSS calibration tool ISical™, makes it fast and easy for non-experts to develop or expand calibrations and transfer them across units.

Robust and low maintenance operation

The ProFoss system keeps on running to ensure high uptime and minimal impact on daily production. Once calibrated, there is no need for constant adjustments caused by drift or other weaknesses. The high stability of the High Resolution technology ensures the same accuracy day in and day out without hidden operational costs.

Intelligent calibration tool - ISical™

Calibration is done either through WinISI™ or by using the new intelligent calibration tool, ISical™. ISical requires a minimum of user experience. Each time a reference sample is collected from the process, a button is pressed on the analyser to synchronise the scan with the collected sample. Reference data is added and a calibration is automatically developed (or an existing calibration expanded with the new data). The new ISical tool automatically optimises the calibration algorithms by selecting the most reliable model for future use.

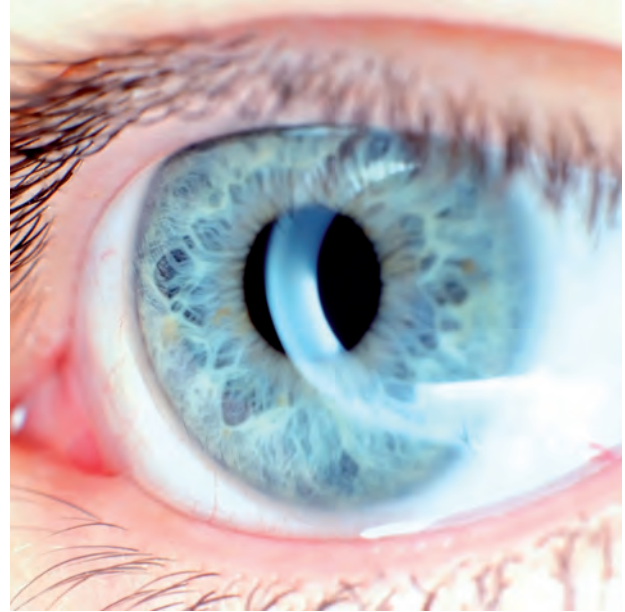
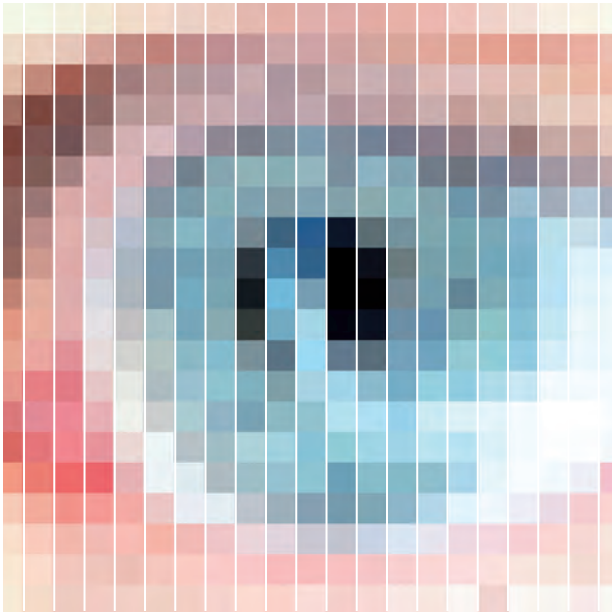

High Resolution near infrared technology gives you a clearer picture of your process. A high number of pixels (diode sensors) in the spectrum secures a more detailed (accurate) and uniform (repeatable) analysis result. High Resolution also enables manufacturing of "identical" (standardised) analysers which stay the same over time (no drift).

The value of a standardised High Resolution analyser

A standardised analyser with transferable calibrations significantly reduces the implementation and maintenance costs.

Transferability is the solid foundation required for rapid implementation of an analyser into a complex process environment. Furthermore, once a calibration has been developed, it can be reused on other analysers.

The key to achieving this is the resolution of the analysers wavelength scale. The FOSS High Resolution technology has one sensor for each nm measured, securing 100% stability of the wavelength scale. In contrast, with lower wavelength resolution, shifts of up to 7 – 8 nm in the wavelength scale can occur, which will require major updates of existing calibrations for each new analyser installed.

FOSS support plans

FossCare™ is a partnership, where FOSS helps customers with preventative maintenance, remote instrument monitoring, consultancy, training programs and breakdown support. FOSS technicians work directly with the customer to solve any problem that they encounter, leading to maximum uptime and increased yield.

By participating in a Preventative Maintenance program, focus is moved from "fix it when it breaks" to a predictable and proactive approach, reducing the cost of unplanned downtime and emergency repairs and increasing the equipment reliability and availability.

Remote Monitoring and diagnostics

RINA is a remote instrument monitoring and diagnostics software that makes it easy for an internal or external expert to precisely configure, monitor and diagnose FOSS instruments from a remote location. Calibration updates and bias corrections are easily handled through the network and the system can be monitored on a daily basis, allowing you to focus on optimising your production.

WPC & MPC solutions from FOSS



MilkoScan™ FT2

The MilkoScan™ FT2 makes the essential job of dairy product standardisation easier and more economic. With the latest in accurate routine testing you can standardise products closer to your set targets for improved profit. Cost effective technology reduces the cost of testing while improving product consistency.

You can also screen for abnormalities with the MilkoScan's unique built-in spectrum screening system at the same time as you carry out normal routine testing.



ProFoss™

Installed in-line, the ProFoss™ gives a continuous flow of "real time" results of the WPC & MPC quality out of the ultra filtration unit. Based on the results the operator or the automatic process regulation system can immediately react to changes in the process. The ProFoss helps you to reduce production variation, produce closer to specifications and streamline your manufacturing process.

FOSS

FOSS
Slangerupgade 69
DK-3400 Hilleroed
Denmark

Tel.: +45 7010 3370
Fax: +45 7010 3371

info@foss.dk
www.foss.dk

